

OPERATION, SERVICE AND PARTS INSTRUCTION MANUAL

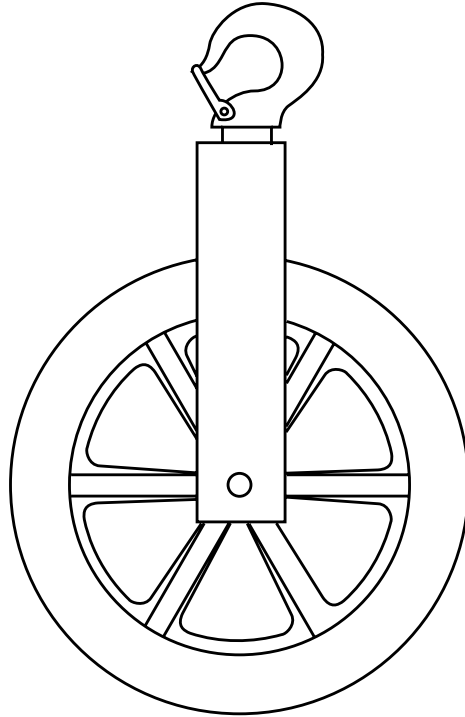

8012, 8018 & 8024 8,000 LB. CAPACITY HOOK-TYPE CABLE SHEAVES



Read and understand this material before operating or servicing this sheave. Failure to understand how to safely operate this sheave could result in an accident causing serious injury or death. This tool should only be operated by qualified personnel.



Purpose of this Manual

Hook sheaves are used to change direction of the pulling rope. This manual provides instructions of rigging hook sheaves and calculating the load on the sheave anchor point and supporting structures.

This manual should be kept available for operating and maintenance personnel. **For additional copies at no charge, order IM-1260 (Part Number 999 2092.1).**



SAFETY ALERT SYMBOL

The symbol above is used to call your attention to instructions concerning your personal safety. Watch for this symbol. It points out important safety precautions. It means **“ATTENTION! Become alert! Your personal safety is involved!”** Read the message that follows and be alert to the possibility of personal injury or death.

⚠ DANGER

Immediate hazards which **WILL** result in severe personal injury or death.

⚠ WARNING

Hazards or unsafe practices which **COULD** result in personal injury or death.

⚠ CAUTION

Hazards or unsafe practices which **COULD** result in minor personal injury or property damage.

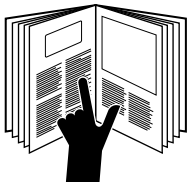

⚠ WARNING

Read and understand all operating and safety instructions before using these sheaves. Failure to properly set up and operate this system could result in an accident causing serious injury or death. This product should only be used by personnel trained in its operation.

SAVE THESE INSTRUCTIONS

Additional copies of this manual and any decals on the product are available upon request at no charge.



SAFE OPERATING PRACTICES

SAVE THESE INSTRUCTIONS

Calculating the Load on the Hook

⚠ WARNING

- Use hook sheaves with a capacity rating **equal to or greater than** that of the maximum force developed by the puller. If you must use an **under-rated sheave**, then you must know that the pull force will not exceed the sheave rating, or you must stop the pull if the force exceeds the sheave rating.
- The load on the hook sheave may be twice that on the rope. Know and understand how to calculate each hook sheave load for each change in rope direction.
- Make sure that all anchors, slings and components of the supporting structure can withstand the loads applied to them.

Failure to observe these warnings could result in the hook sheave breaking its mounting and striking nearby personnel, causing serious injury or death.

CHART #1

QUICK REFERENCE CHART		
ROPE	ANGLE	ADDED LOAD ON HOOK (R)
	straight	0
	150°	.52 x T
	135°	.77 x T
	120°	1 x T
	90°	1.41 x T
	60°	1.73 x T
	45°	1.85 x T
	30°	1.93 x T
	full return	2 x T
		T = Pulling Force on Rope

FORMULA #1

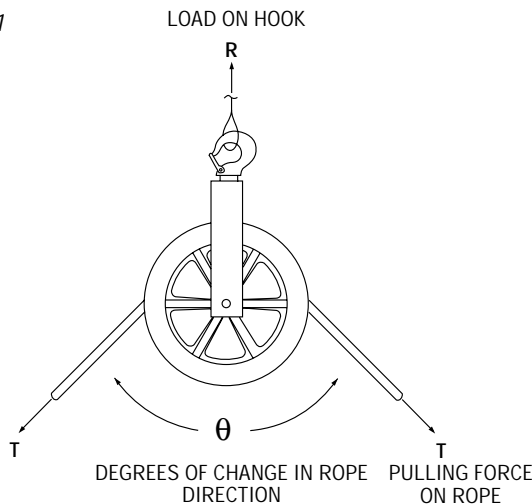

FORMULA FOR CALCULATING HOOK AND STRUCTURE LOAD (SINGLE HOOK SHEAVE)

- θ = Degrees of change in rope direction
- T = Rope Tension
- R = Load on Hook and mounting structure

$$R = 2 \times T \times \text{SIN} ((180 - \theta) / 2)$$



SAFE OPERATING PRACTICES

SAVE THESE INSTRUCTIONS

CAUTION

Check the angle the rope makes over the sheave. Determine the load on the hook and supporting structures, and be sure they will withstand the load.

A rope making a 120° bend over the sheave adds the total pulling force to the load on the hook and structure.

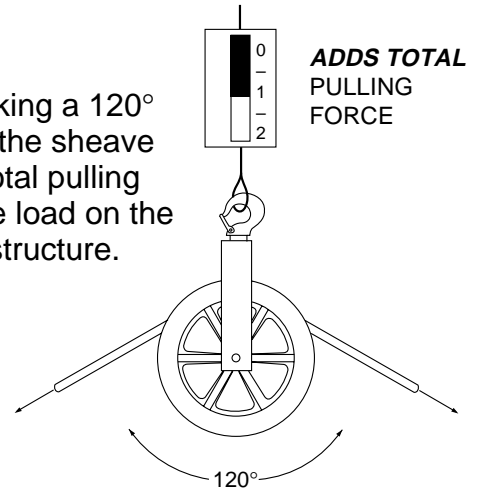

ADDS TOTAL PULLING FORCE

A straight rope will not add any load to the hook and structure.

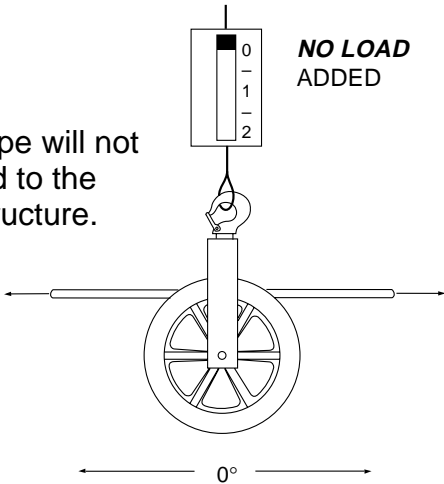

NO LOAD ADDED

A rope making a 90° bend over the sheave adds nearly one and a half times pulling force to the load on the hook and structure.

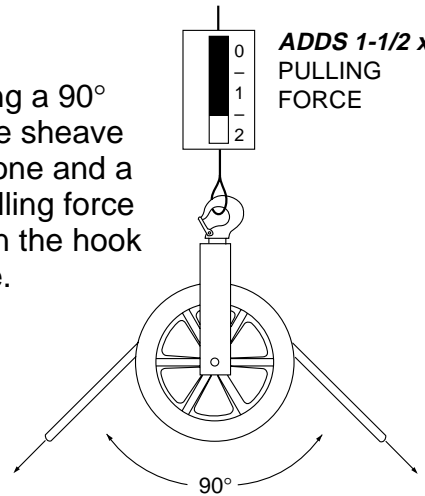

ADDS 1-1/2 x PULLING FORCE

A rope making a 150° bend over the sheave adds half the pulling force to the load on the hook and structure.

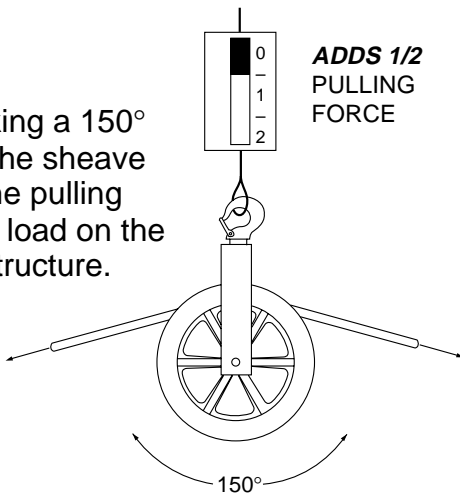

ADDS 1/2 PULLING FORCE

A rope making a full return bend over the sheave adds double the total pulling force to the load on the hook and structure.

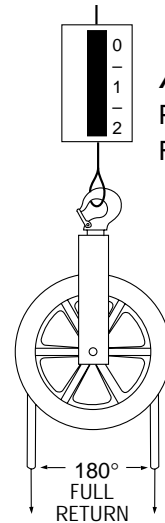

ADDS TWICE PULLING FORCE



SAFE OPERATING PRACTICES

SAVE THESE INSTRUCTIONS

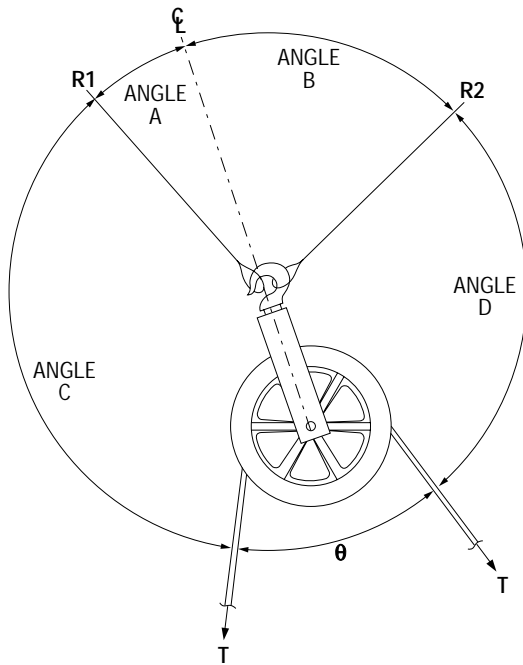

Figure 2 - Single Hook Sheave with two attachment points

CALCULATING THE LOAD ON SINGLE HOOK SHEAVES with two attachment points (Figure 2)

- Determine the load on the sheave from Chart #1 “Quick Reference Chart” or Formula #1 (page 3).
- Determine the angles “A” and “B” (Figure 2) by extending an imaginary line beyond the yoke as illustrated
OR
- Determine the angles “A” and “B” (Figure 2) by measuring angles “C” and “D” and using Formula #2 below.
- Calculate the loads R1 and R2 using Formula #3 below

FORMULA #2

FORMULA FOR CALCULATING ANGLES “A” AND “B”

Measure angles “C” and “D” (see Figure 2)

$$\text{ANGLE A} = 180^\circ - 1/2 \theta - C$$

$$\text{ANGLE B} = 180^\circ - 1/2 \theta - D$$

FORMULA #3

FORMULA FOR CALCULATING HOOKS AND STRUCTURES LOADS (Twin Yoke Sheaves or Single Hook Sheaves with two attachment points)

WHERE:

$$R1 = \frac{R}{\cos A + \sin A / \tan B}$$

$$R2 = \frac{R}{\cos B + \sin B / \tan A}$$

R = Added Load on Sheave (from page 3)

R1 = Load on left mounting

R2 = Load on right mounting

θ = Degrees of change in rope direction

A = Degrees between left mounting line and centerline of rope legs

B = Degrees between right mounting line and centerline of rope legs

C = Centerline between rope legs

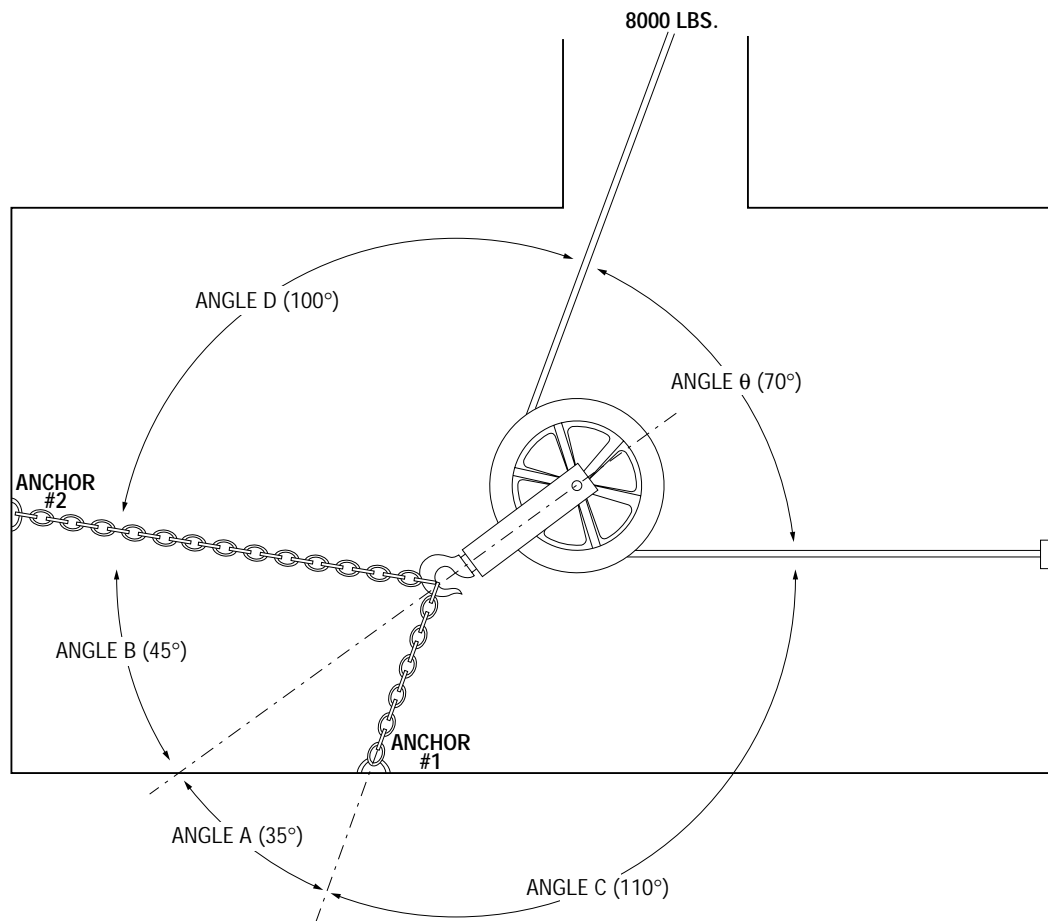
Example:

In this example we'll pull up out of a manhole using the Ultra Tugger™ cable puller. The pull force is unknown so we'll assume the maximum rope tension will be 8000 pounds. First, we'll need to measure some angles.

1. We measure angle θ between the rope legs as 70 degrees.
2. We measure angle A between the extended line of the frame and one anchor line either directly as 35 degrees or by measuring angle C as 110 degrees and calculating angle A from Formula #2:

$$A = 180 - 1/2 \times \theta - C = 180 - 1/2 \times 70 - 110 = 35 \text{ degrees}$$

3. We measure angle B between the extended line of the frame and the second anchor line either directly as 45 degrees or by measuring angle D as 100 degrees and calculating angle B from Formula #2:

$$B = 180 - 1/2 \times \theta - D = 180 - 1/2 \times 70 - 100 = 45 \text{ degrees}$$

4. Calculate the hook load "R" from Formula #1:

$$R = 2 \times T \times \sin((180-\theta)/2) = 2 \times 8000 \times \sin((180-70)/20) = 16000 \times \sin(55) = 13106 \text{ pounds}$$

5. Calculate the loads on anchor points 1 and 2 from Formula #3:

$$R1 = R / \{\cos(A) + \sin(A) / \tan(B)\} = 13106 / \{\cos(35) + \sin(35) / \tan(45)\} = 9410 \text{ pounds}$$

$$R2 = R / \{\cos(B) + \sin(B) / \tan(A)\} = 13106 / \{\cos(45) + \sin(45) / \tan(35)\} = 7633 \text{ pounds}$$

Summary:

Rope Tension: 8,000 lbs.

Load on Hook: 13,106 lbs.

Load on Chain 1 and Anchor 1: 9,410 lbs.

Load on Chain 2 and Anchor 2: 7,633 lbs.

REPRINTED WITH PERMISSION BY THE CROSBY GROUP

Crosby Hoist Hook

Warnings and Application Instructions

⚠ WARNING

- Loads may disengage from hook if proper procedures are not followed.
- A falling load may cause serious injury or death.
- See OSHA Rule 1926.550(g) for personnel hoisting by cranes or derricks. A Crosby 319, 320, or 322 hook with a PL Latch attached (when secured with the bolt, nut and pin) may be used for lifting personnel.
- Threads may corrode and/or strip and drop the load.
- Hook must always support the load. The load must never be supported by the latch.
- Never apply more force than the hook's assigned Working Load Limit (WLL) rating.
- Read and understand these instructions before using hook.

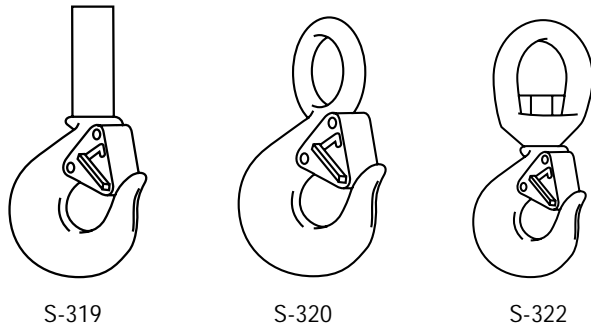

Important Safety Information - Read and Follow:

- Always visually inspect hook before using.
- Inspect hook and threads with magnetic particle and/or dye penetrate annually, or more often in severe operating conditions.

Note: Some Disassembly may be required.

- Never use a hook whose throat opening has been increased, or whose tip has been bent more than 10 degrees out of plane from the hook body, or is in any other way distorted or bent.

Note: A latch will not work properly on a hook with a bent or worn tip.

- Never use a hook that is worn beyond the limits shown in Figure 1.
- Remove from service any hook with a crack, nick, or gouge. Hooks with a crack, nick, or gouge shall be repaired by grinding lengthwise, following the contour of the hook, provided that the reduced dimension is within the limits shown in Figure 1.
- Never repair, alter, rework, or reshape a hook by welding, heating, burning, or bending.

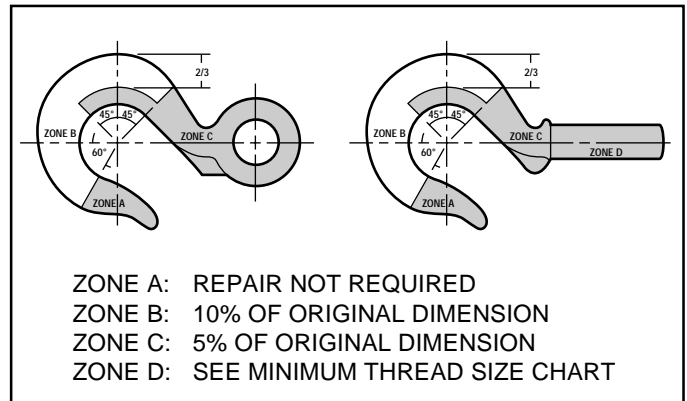

Figure 1

- Never side load, back load, or tip load a hook. (See Figure 2.)
- Eye hooks, shank hooks and swivel hooks are designed to be used with wire rope or chain. Efficiency of assembly may be reduced when used with synthetic material.
- Do not swivel the S-322 swivel hook while it is supporting a load.
- The use of a latch may be mandatory by regulations or safety codes; e.g., OSHA, MSHA, ANSI/ASME B30, Insurance, etc.

Note: When using latches, see instructions in "Understanding: The Crosby Group Warnings" for further information.

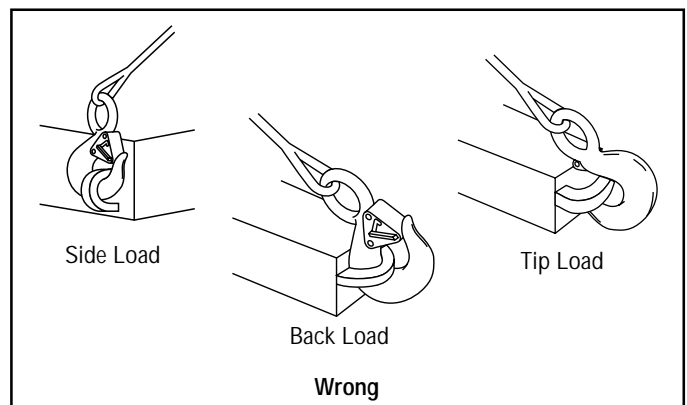

Figure 2

REPRINTED WITH PERMISSION BY THE CROSBY GROUP

- Always make sure the hook supports the load. (See Figure 3.) The latch must never support the load (See Figure 4).

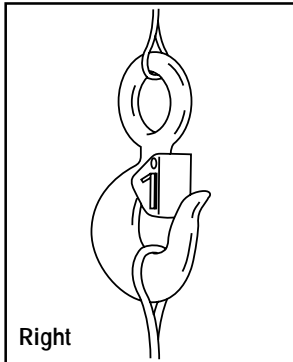

Figure 3

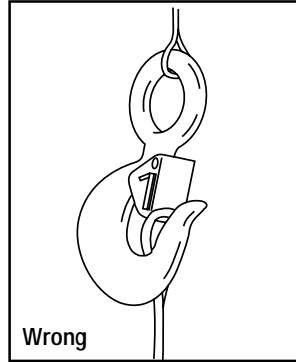

Figure 4

- When placing two (2) sling legs in hook, make sure the angle from the vertical to the outermost leg is not greater than 45°, and the included angle between the legs does not exceed 90° (See Figure 5).
- See ANSI/ASME B30.10 "Hooks" for additional information.

* For angles greater than 90°, or more than two (2) legs, a master link or bolt-type anchor shackle should be used to attach the legs of the sling to the hook.

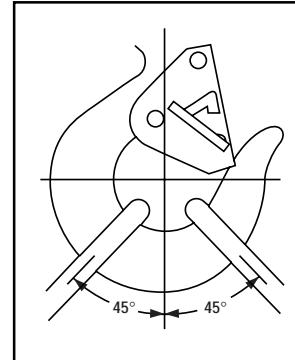

Figure 5

Warnings and Application Instructions

Important Safety Information - Read and Follow:

- Always inspect hook and latch before using.
- Never use a latch that is distorted or bent.
- Always make sure spring will force the latch against the tip of the hook.
- Always make sure hook supports the load. The latch must never support the load. (See Figures 1 & 2.)
- When placing two (2) sling legs in hook, make sure the angle between legs is small enough and the legs are not tilted so that nothing bears against the bottom of the latch. (See Figures 3 & 4.)
- Latches are intended to retain loose sling or devices under slack conditions.
- Latches are not intended to be an anti-fouling device.

⚠ WARNING

- Loads may disengage from hook if proper procedures are not followed.
- A falling load may cause serious injury or death.
- See OSHA Rule 1926.550(g) for personnel hoisting by cranes or derricks. A Crosby or McKissick hook and this latch (when secured with the bolt, nut and pin) may be used for lifting personnel.
- Hook must always support the load. The load must never be supported by the latch.
- Read and understand these instructions before using hook.

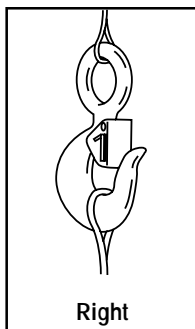

Figure 1

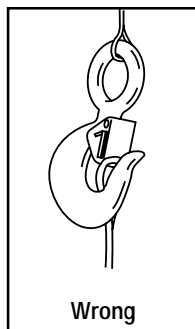

Figure 2

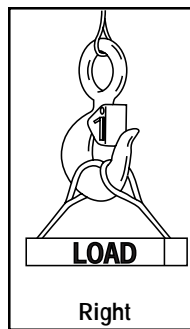

Figure 3

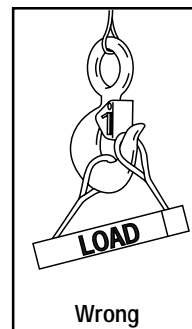
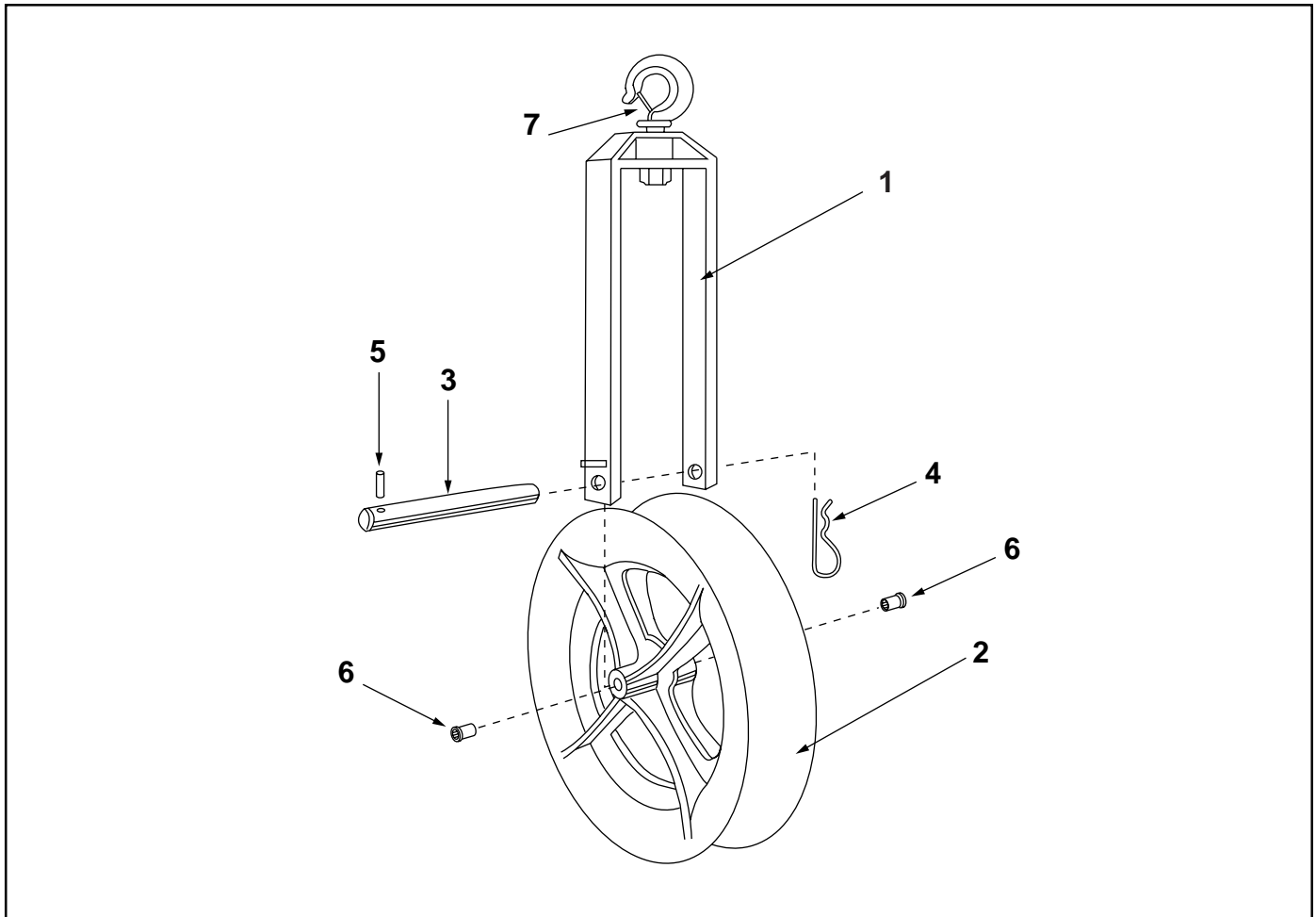

Figure 4



Parts List

KEY NO.	DESCRIPTION	QTY.	PART NO. FOR 8012	PART NO. FOR 8018	PART NO. FOR 8024
1	Frame Unit	1	500 0854.4	500 0855.2	500 0856.0
2	Sheave Unit (with #6)	1	500 0843.9	500 0844.7	500 0845.5
3	Sheave Pin	1	500 0838.2	500 0846.3	500 0850.1
4	#8 Hitch Pin Clip	1	905 0302.3	905 0302.3	905 0302.3
	Decal	1	501 2121.9	501.2121.9	501 2121.9
5	Roll Pin, 3/16 x 1.50	1	905 0700.2	905 0700.2	905 0700.2
6	Bearing	2	905 4838.8	905 4838.8	905 4838.8
7	Latch Unit	1	905 4185.5	905 4185.5	905 4185.5

GREENLEE **TEXTRON**

Greenlee Textron Inc. / Subsidiary of Textron Inc.

4455 Boeing Drive, Rockford, IL 61109-2988 USA

General Offices: 815/397-7070

Customer Center and Field Service: 800/435-0786

Fax (24 Hour) Customer Center: 800/451-2632 • 815/397-1865

Canada Fax (24 Hour) Customer Center: 800/524-2853

Printed in U.S.A.